

HYDAC DC Compact Power Units DC1

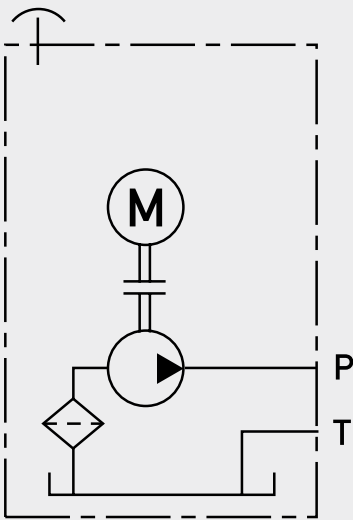

up to 250 bar
up to 18.4 l/min

In accordance with EN 60034-1
suitable for short-term operation



1. TECHNICAL SPECIFICATIONS

1.1 GENERAL

- Very low noise level due to special construction
- Space-saving design due to small flange
- Possibility of different hydraulic controls in the same flange due to flexible configuration of cartridge valves and/or fitting of control blocks and serial function modules

1.2 SAFETY INSTRUCTIONS

Observance of the safety instructions is of the utmost importance. Before commissioning, the safety instructions must be read and followed without fail – see point 8! Failure to observe these instructions will invalidate the product warranty.

1.3 HYDRAULIC DETAILS

Flow rate Q	up to 18.4 l/min
Continuous pressure	up to 250 bar
Peak pressure	up to 300 bar (on request) (possible with a reduced number of cycles depending on pump size!)
Motor	1.7 – 3.0 kW
Protection class	DIN EN 60034-5 min. IP 54
Pump displacement	1.0 – 8 cm ³
Tank volume	draw-off/useable volume 1.2 l – 7.8 l
Duty cycle	see point 4
Operating fluid	mineral oil to DIN 51524 Part 2
Temperature range of operating fluid	min. –20 °C to max. +80 °C
Viscosity range	min. 10 mm ² /s – max. 380 mm ² /s
Filtration	operating fluid to ISO 4406 Class 21/19/16 or cleaner
Ambient temperature	–20 °C to +40 °C
Return flow rate	up to maximum 40 l/min

1.4 MECHANICAL AND ELECTRICAL DETAILS

Pressure-compensated external gear pump, direction of rotation: anti-clockwise

Mechanical characteristics:

Type of mounting:
2 x M10 (min. 8.8) threads on underside of mounting flange, see point 3.6 Mounting options

Weight of basic unit:
DC1 with 1.7 – 2.2 kW motor approx. 15 kg (without oil)

DC1 with 3 kW motor approx. 20 kg (without oil)

Mounting position: horizontal (standard), vertical possible

1 Suction line (vertical in mounting position)

2 Suction strainer 350 µm

3 Oil drain plug

4 Return line (vertical in mounting position)

5 Clamp

6 Breather filter

7 Plastic oil tank (see point 3.3, Oil tank) in PE, semi-transparent with oil level markings
– depending on the application, provide as much support to tank as possible (see point 3.5)
– do not expose to direct sunlight over long periods

8 Flange enables a variety of different hydraulic controls due to versatile configuration of cartridge valves – see point 4 for application examples

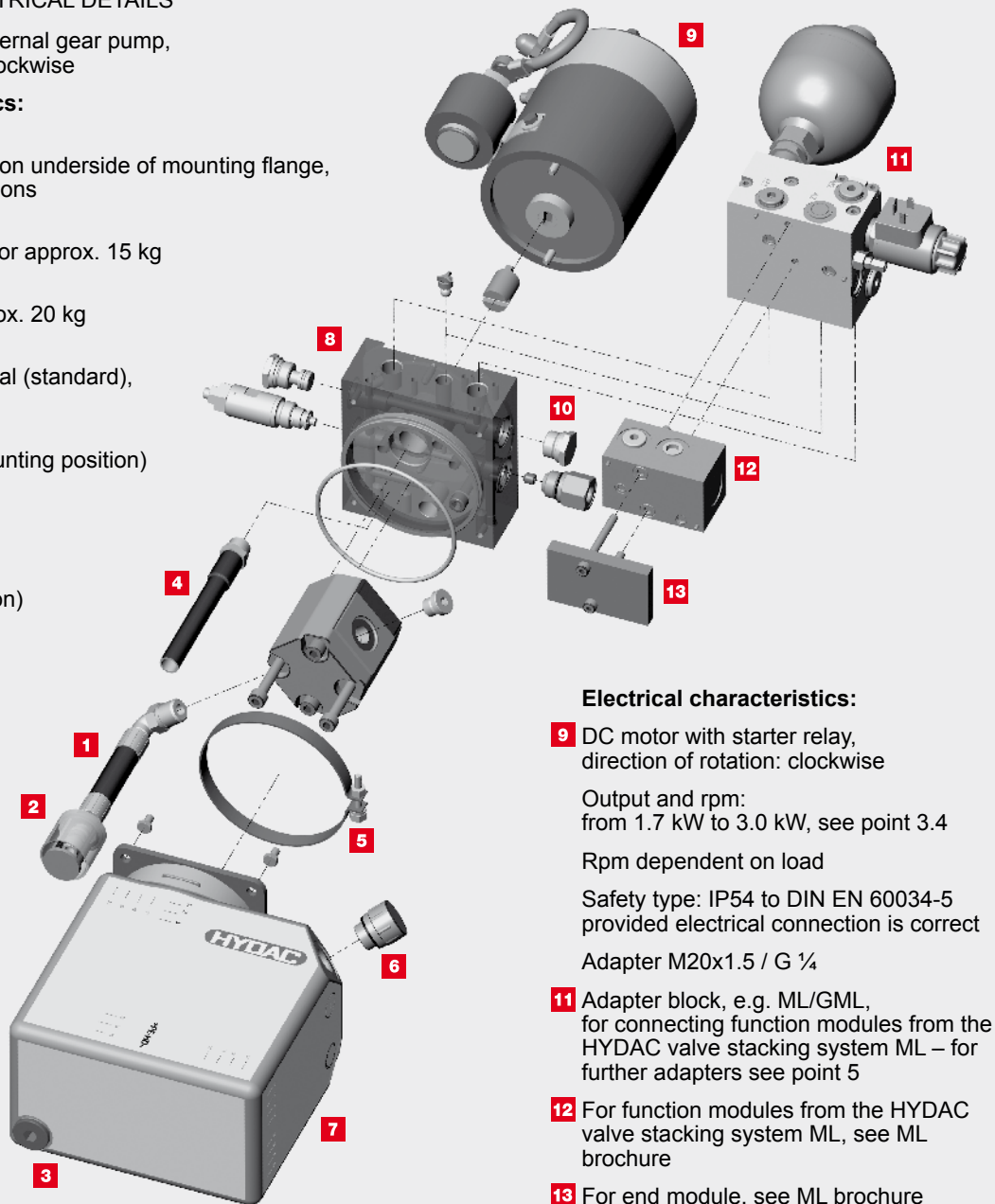

Electrical characteristics:

- 9** DC motor with starter relay, direction of rotation: clockwise
Output and rpm: from 1.7 kW to 3.0 kW, see point 3.4
Rpm dependent on load
Safety type: IP54 to DIN EN 60034-5 provided electrical connection is correct
Adapter M20x1.5 / G ¼
- 11** Adapter block, e.g. ML/GML, for connecting function modules from the HYDAC valve stacking system ML – for further adapters see point 5
- 12** For function modules from the HYDAC valve stacking system ML, see ML brochure
- 13** For end module, see ML brochure

2. MODEL CODE

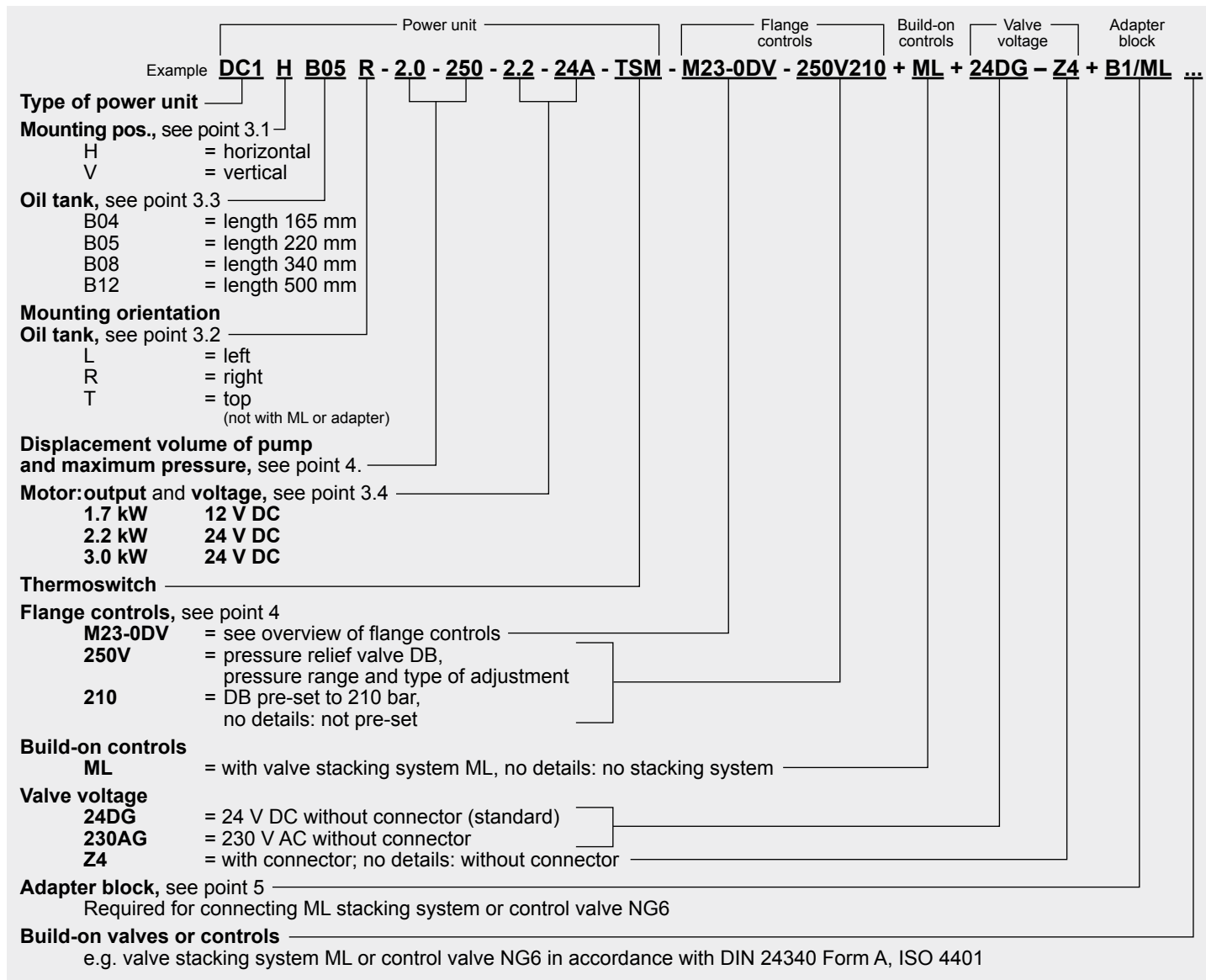

3. TECHNICAL DETAILS AND DIMENSIONS

3.1 MOUNTING POSITION OF POWER UNIT

H = horizontal

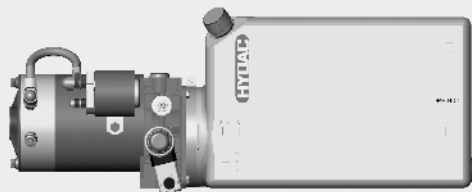

V = vertical



3.2 MOUNTING ORIENTATION OF OIL TANK

L = left

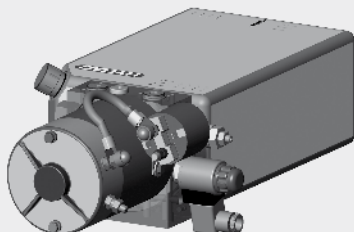

T = top

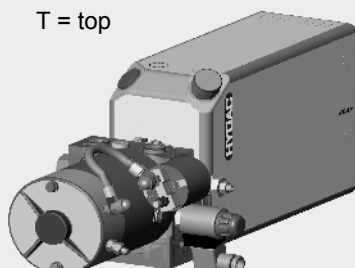

R = right

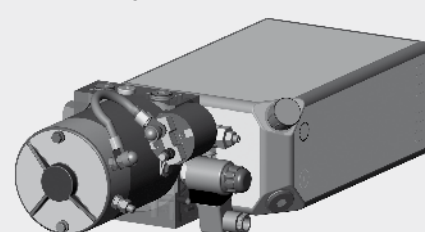

3.3 OIL TANK

Tank code	Filling volume / draw-off volume [l]**			Tank length [mm]
	Horizontal tank position R and L	Horizontal tank position T**	Vertical	
B04***	1.9/1.5	2.2/2.0	1.8/1.2	165*
B05	2.7/2.2	3.0/2.7	3.0/2.4	220*
B08	4.4/3.5	5.1/4.6	5.1/4.5	340*
B12	6.5/5.2	8.4/7.6	8.4/7.8	500*

* where mounted horizontally, support for oil tank must be provided by the customer – see dimensions

** cannot be selected if adapter blocks are to be fitted (see point 6)

*** can only be used up to pump size 3.75

**** The usable volume given is the maximum value (will be achieved with a clean suction filter, low to medium flow rate and viscous fluid!)

3.5 DIMENSIONS

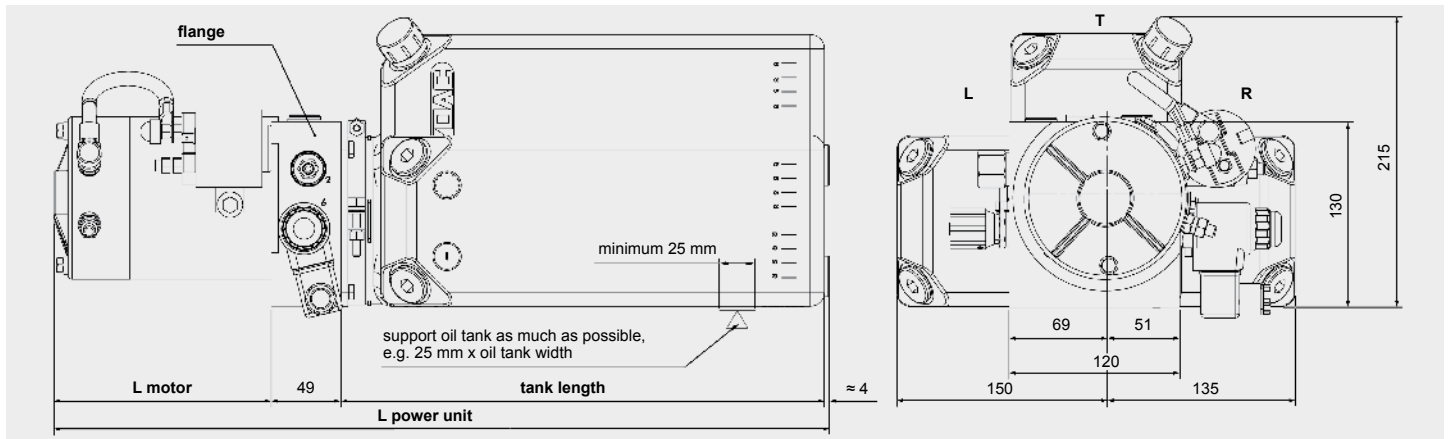

Motor performance DC [kW]	Voltage DC [V]	L motor [mm]	Thermoswitch
1.7	12	approx. 156	TS
2.2	24	approx. 156	TS
3	24	approx. 205	TS

3.6 MOUNTING OPTIONS ON FLANGE UNDERSIDE

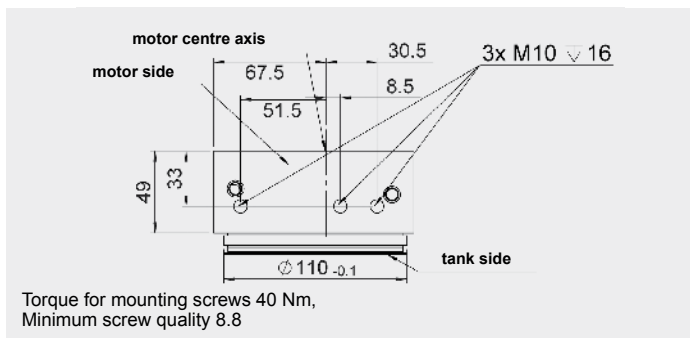

3.7 CAVITIES IN DC1 FLANGE

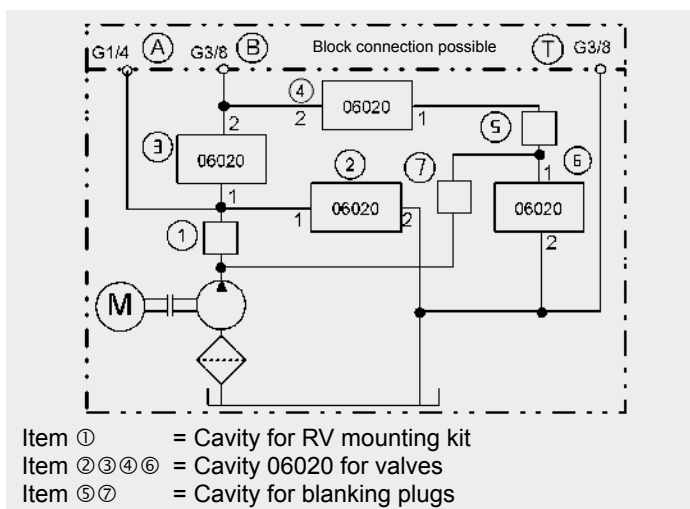

3.4 FLANGE DIMENSIONS (M23Z-DV-A/M)

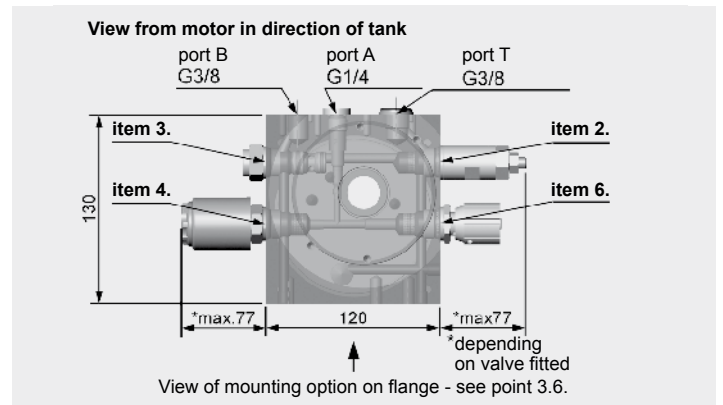

3.8 FLANGE CONTROLS (also see point 5) BASIC CONTROL M00

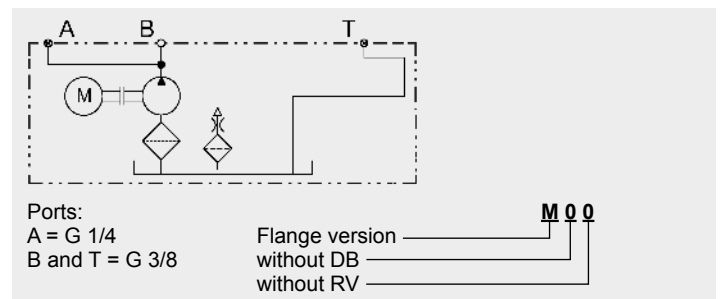

3.9 VALVES FOR 06020 CAVITY

Type	250V CE210	DB4E (brochure no. 5.161) DB4E-CE (brochure no. 5.163)
V		WSM 06020 V-01 (brochure no. 5.949.1)
W		WSM 06020 W-01 (brochure no. 5.949.3)
WN		WSM 06020 W-01J (brochure no. 5.949.3)
Y		WSM 06020 Y-01 (brochure no. 5.947)
Z		WSM 06020 Z-01 (brochure no. 5.943)
ZN		WSM 06020 Z-01J (brochure no. 5.949.2)
DV		DV5E (brochure no. 5.113)
SR		SR5E (brochure no. 5.117)
A3 A4		Adapter M20x1.5 – G¼ for build-on parts
0		Long blanking plug (closed)
0		Short blanking plug (open)

4. PUMP – MOTOR CHARACTERISTICS

4.1 PUMP – MOTOR CHARACTERISTICS: 1.7 KW – 12 V

Pump displacement [ccm]	Pressure [bar]				
	50	100	150	200	250
1.0	3.3 l/min 80 A 10 min 26 %	3.2 l/min 110 A 10 min 26 %	2.9 l/min 130 A 8 min 20 %	2.8 l/min 164 A 6 min 16 %	2.7 l/min 175 A 4.5 min 13 %
2.0	6.5 l/min 110 A 10 min 25 %	6.0 l/min 160 A 6 min 16 %	5.4 l/min 220 A 3.5 min 10 %	4.9 l/min 264 A 2.5 min 6 %	4.6 l/min 317 A 1.7 min 5 %
2.65	8.3 l/min 125 A 8 min 21 %	7.3 l/min 200 A 4 min 11 %	6.6 l/min 260 A 2 min 7 %	6.0 l/min 367 A 1.5 min 4 %	
3.75	10.8 l/min 150 A 6 min 17 %	9.1 l/min 250 A 3 min 7.5 %	8.2 l/min 340 A 1.5 min 4 %		
4.75	13 l/min 175 A 5 min 12.5 %	10.8 l/min 280 A 2 min 6 %			
6.3	16.4 l/min 220 A 3 min 9 %				
8.0	18.1 l/min 250 A 3 min 7.5 %				

Q: [l/min]
I: A]
S2: [min]
S3: [%]

4.2 PUMP – MOTOR CHARACTERISTICS: 2.2 KW – 24 V

Pump displacement [ccm]	Pressure [bar]				
	50	100	150	200	250
1.0	3.4 l/min 35 A 5.5 min 12 %	3.2 l/min 50 A 5.5 min 12 %	3.0 l/min 70 A 5 min 11 %	2.8 l/min 77 A 4 min 9 %	2.7 l/min 90 A 3 min 7 %
2.0	6.5 l/min 55 A 5.5 min 12 %	5.9 l/min 80 A 4 min 8 %	5.4 l/min 110 A 2 min 5.5 %	4.9 l/min 130 A 1 min 4 %	
2.65	8.3 l/min 65 A 5.5 min 12 %	7.3 l/min 100 A 2.5 min 6 %	6.5 l/min 130 A 1 min 4 %		
3.75	10.9 l/min 75 A 4.5 min 9 %	9.2 l/min 120 A 1.5 min 4.5 %			
4.75	12.9 l/min 90 A 3.5 min 7.5 %	10.6 l/min 155 A 0.8 min 3.5 %			
6.3	16.2 l/min 110 A 2 min 5.5 %				
8.0	18.4 l/min 125 A 1.5 min 4.5 %				

Q: [l/min]
I: A]
S2: [min]
S3: [%]

4.3 PUMP – MOTOR CHARACTERISTICS: 3.0 KW – 24 V

Pump displacement [ccm]	Pressure [bar]				
	50	100	150	200	250
1.0	4.1 l/min 40 A 10 min 34 %	3.8 l/min 57.5 A 10 min 32 %	3.7 l/min 80 A 9 min 30 %	3.5 l/min 90 A 8 min 25 %	3.4 l/min 92.5 A 7 min 22 %
2.0	8.0 l/min 67.5 A 9.5 min 34 %	7.3 l/min 100 A 8 min 24 %	6.9 l/min 137.5 A 6 min 20 %	6.5 l/min 170 A 4.5 min 16 %	5.9 l/min 200 A 3.5 min 12.5 %
2.65	10.4 l/min 75 A 9 min 30 %	9.4 l/min 120 A 6 min 21 %	8.7 l/min 170 A 4.5 min 16 %	7.7 l/min 212.5 A 3 min 12 %	
3.75	13.4 l/min 93 A 8 min 26 %	11.9 l/min 160 A 5 min 17 %	10.4 l/min 215 A 3 min 12 %		
4.75	16 l/min 110 A 5.5 min 22 %	13.7 l/min 185 A 4 min 14 %			

Q: [l/min]
I: A]
S2: [min]
S3: [%]

5. FLANGE CONTROLS

5.1 BASIC CONTROL M21

Flange version ———— **M 2 1**
 with pressure relief valve, item 2 ————
 with check valve, item 1 ————

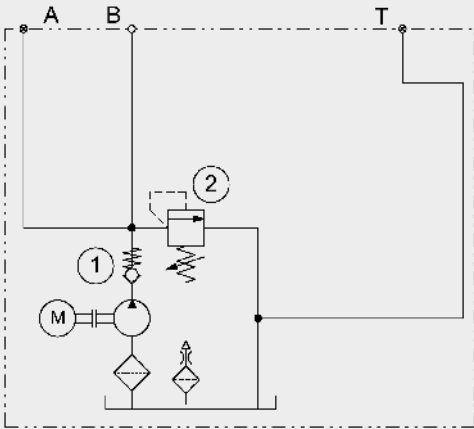

Ports:
 A = G 1/4
 B and T = G 3/8

For further technical information
 on valves see:

DB4E Brochure no. 5.161../..
 and 5.163../..
 DV5E Brochure no. 5.113../..
 WSM 06020 Brochure no. 5.949../..

Example: **M21-A3 A4 DV-CE210-MA2-EDS3-SBO3**

Supplied loose, see page 9 ————

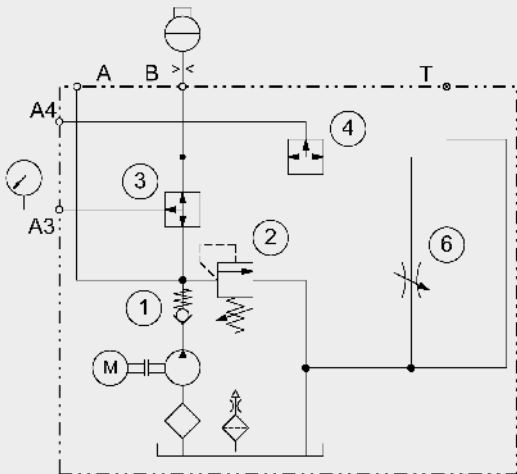

Ports:
 A = G 1/4, B and T = G 3/8
 A3 and A4 = G 1/4
 (Adapter M 20 x 1.5-G 1/4)

ACCUMULATOR CHARGING CONTROL

Example: **M 2 1 - A3 A4 DV - CE210 + 24DG**

Flange version metric	—————	M 2 1	—————
Item 2 Pressure relief valve DB4E	—————	2	—————
Item 1 Check valve EBS RV06	—————	1	—————
Item 3 Blanking plug	—————	0	—————
Port with adapter M20x1.5 / G1/4	—————	A3	—————
Item 4 Blanking plug	—————	0	—————
Port with adapter M20x1.5 / G1/4	—————	A4	—————
Item 6 Blanking plug	—————	0	—————
Flow control valve DV5E	—————	DV	—————
WSM06020W...01M...with M/O*	—————	WN	—————
WSM06020V...	—————	V	—————
DB4E...CE...type-approved	—————	CE210	—————
Pressure setting DB4E e.g. 210 bar	—————		
Valve voltage	24 V DC = 24DG		
	230 V AC = 230AG		

For further build-on parts
see point 7.

For more detailed information on build-on parts for A3 / A4, see page 9.

5.2 BASIC CONTROL M23

Flange version ———— **M 2 3**
 with pressure relief valve, item 2 ————
 with check valve, item 3 ————

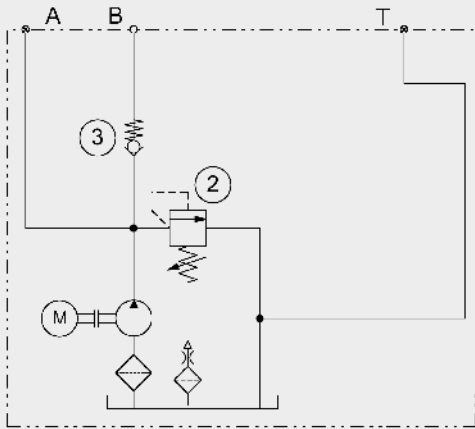

Ports:
 A = G 1/4
 B and T = G 3/8

For further technical information
 on valves see:

DB4E	Brochure no. 5.161../..
RVM 06020	Brochure no. 5.193../..
DV5E	Brochure no. 5.113../..
WSM 06020	Brochure no. 5.949../..
SRE	Brochure no. 5.118../..
SR5E	Brochure no. 5.117.4../..

Example: **M23-ZNDV-250V**

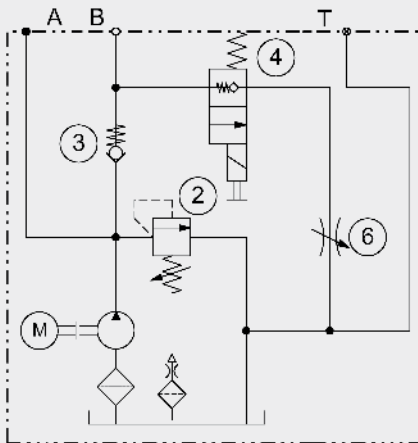

Ports:
 A = G 1/4
 B and T = G 3/8

Example: **M23-ZN SR2.5-250V**

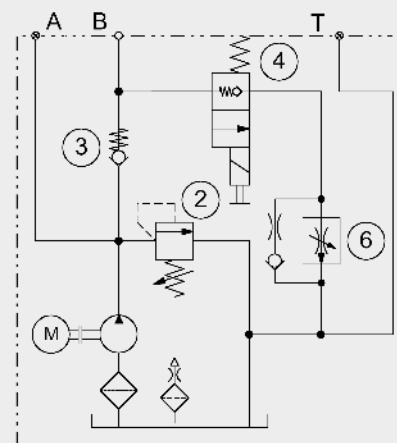

Ports:
 A = G 1/4
 B and T = G 3/8

LIFT-LOWER CONTROL

Example: **M 2 3 - ZN DV - 250V + 24DG**

Flange version metric	—————	M
Item 2 Pressure relief valve DB4E	—————	2
Item 3 Check valve RVM06020	—————	3
Item 4 Blanking plug	—————	0
Adapter M20x1.5 / G1/4	—————	A4
WSM06020Z	—————	Z
WSM06020Z...01M...with M/O* (standard)	—————	ZN
WSM06020Y	—————	Y
WSM06020W...01M...with M/O* (standard)	—————	WN
Item 6 Blanking plug	—————	0
Flow control valve DV5E (standard)	—————	DV
Pressure comp. flow control valve SR5E	—————	SR
WSM06020V	—————	V
WSM06020W	—————	W
WSM06020W...01M...with M/O* (standard)	—————	WN
Pressure relief valve not pre-set (p _{max} 250 bar)	—————	24DG
Valve voltage	—————	230AG

For further build-on parts
see point 7.

*M/O = Manual override

BASIC CONTROL M61

Flange version ———— **M 6 1**
 with pressure relief valve, item 6 ————
 with check valve, item 1 ————

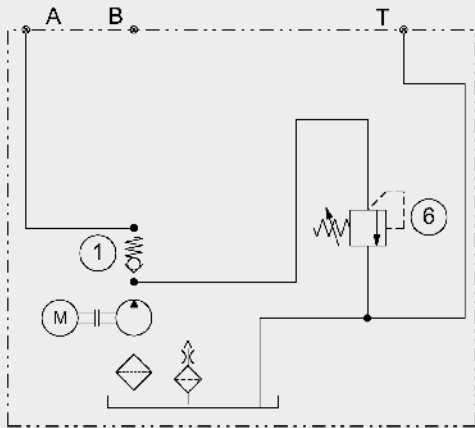

Ports:
 A and A4 = G 1/4
 B and T = G 3/8

For further technical information
 on valves see:

- | | |
|-----------|---------------------------|
| DB4E | Brochure no. 5.161../.. |
| RVM 06020 | Brochure no. 5.193../.. |
| DV5E | Brochure no. 5.113../.. |
| WSM 06020 | Brochure no. 5.949../.. |
| SRE | Brochure no. 5.118../.. |
| SR5E | Brochure no. 5.117.4../.. |

Example: **M61-WNZN-A4/S4.0-250V200**

Unpressurized circulation

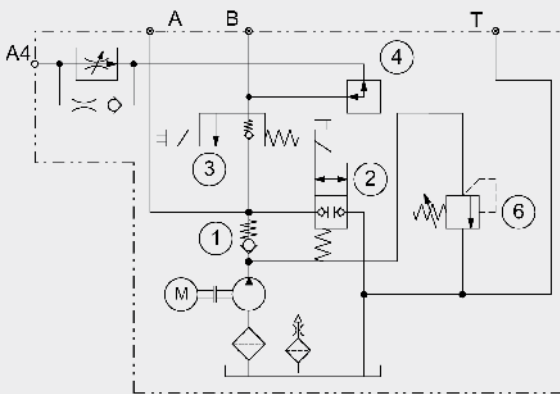

Ports:
 A and A4= G 1/4
 B and T = G 3/8

Example: **M61-WN0-A4/S4.0-250V200**

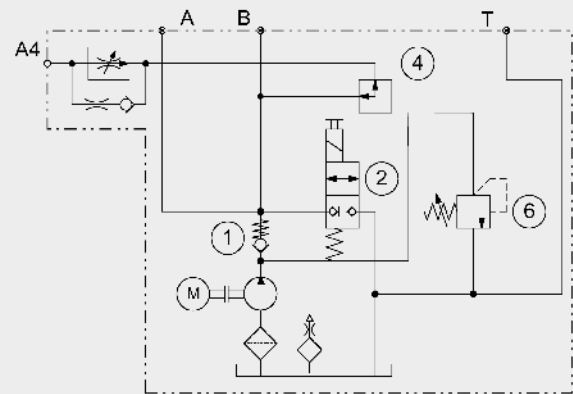

Ports:
 A and A4= G 1/4
 B and T = G 3/8

LIFT-LOWER CONTROL

Example: **M 6 1 - WNZN - A4/S4.0 - 250V200 + 24DG**

Flange version metric	—————	M 6 1
Item 6	Pressure relief valve DB4E	—————
Item 1	Check valve EBS RV06	—————
Item 2	no details = no control valve	0
	WSM06020W...	W
	WSM06020W...01M...with M/O*	WN
	WSM06020V...	V
Item 3	no details = no control valve	0
	Adapter M20x1.5 / G1/4	A3
	WSM06020Z...	Z
	WSM06020Z...01M...with M/O*	ZN
Item 4	no details = no port A4	0
	Port with adapter M20x1.5 / G1/4	A4
	Adapter with flow control valve	A4 /
	SRE1 (built-on), see point Punkt 7.1	S4.0
	Pressure relief valve (p _{max} 250 bar) 200 bar pre-set	—————
Valve voltage	24 V DC = 24DG	—————
	230 V AC = 230AG	—————

For further build-on parts
 see point 7.

*M/O = Manual override

6. ADAPTER BLOCKS

Type:
DC1...M61...ML... + **B1/20** +...

Block for mounting base modules from the HYDAC valve stacking system ML (see ML brochure)

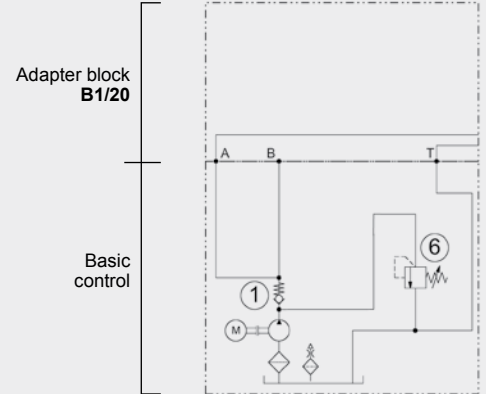
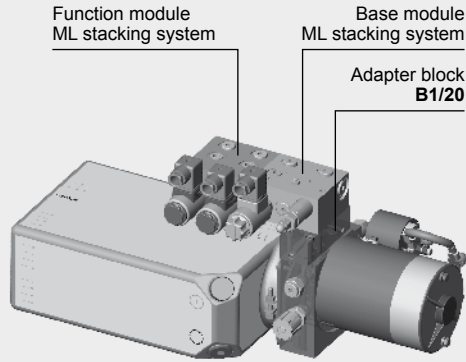

Type:
DC1...M21...ML... + **B1/GML** +...

Block for mounting function modules from the HYDAC valve stacking system ML (see ML brochure), suitable for optional mounting of an accumulator, with manually-operated pressure release (3)

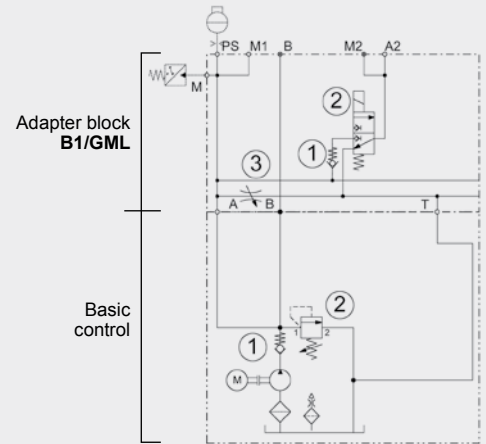
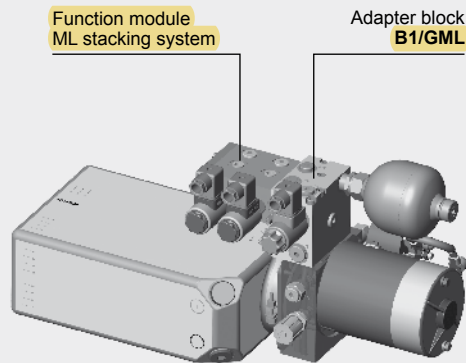

For further technical information on valves see:

DB4E	brochure no. 5.161./...
DV5E	brochure no. 5.113./...
WSM 06020	brochure no. 5.949./...
SRE	brochure no. 5.118./...

Type:
DC1...M61...ML... + **B1/ML** +...

Block for mounting function modules from the HYDAC valve stacking system ML (see ML brochure)

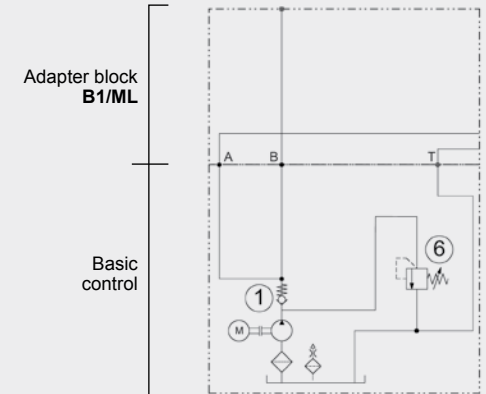
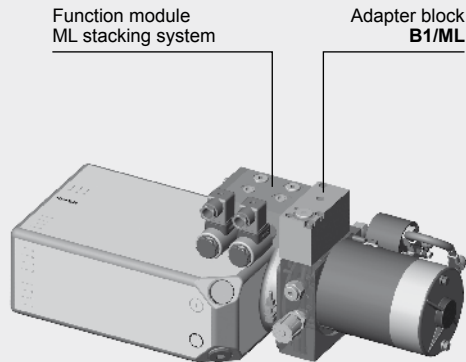

Type:
DC1...M61... + **B1/A6** +...

Block for mounting control valves, nominal size 6 in accordance with DIN 24340 Form A, ISO 4401. When fitting several control valves, extension module 3A6 is required (see ML brochure)

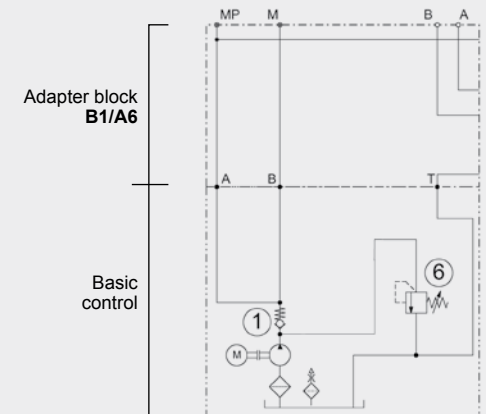
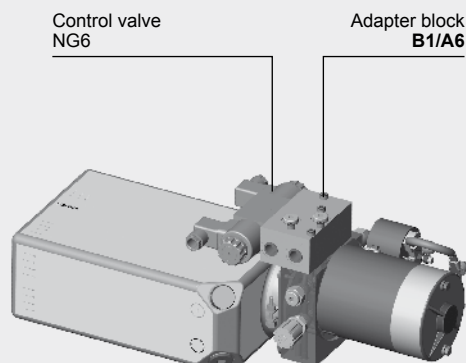

7. BUILD-ON PARTS FOR A, A3, A4 (on A3, A4 with adapter M20x1.5 / G1/4)

Example **DC1... - A4 / MA4 + ...**

7.1 FLOW CONTROL VALVES - supplied fitted -

- S1.6** Pressure compensated flow control valve SRE1 with pre-set flow rate = 1.6 l/min (Part No. 3055053)
- S2.5** Pressure compensated flow control valve SRE1 with pre-set flow rate = 2.5 l/min (Part No. 3055131)
- S4.0** Pressure compensated flow control valve SRE1 with pre-set flow rate = 4.0 l/min (Part No. 554533)
- S5.0** Pressure compensated flow control valve SRE1 with pre-set flow rate = 5.0 l/min (Part No. 558362)
- S6.0** Pressure compensated flow control valve SRE1 with pre-set flow rate = 6.0 l/min (Part No. 554534)
- S8.0** Pressure compensated flow control valve SRE1 with pre-set flow rate = 8.0 l/min (Part No. 554535)
- S10.0** Pressure compensated flow control valve SRE1 with pre-set flow rate = 10.0 l/min (Part No. 554536)
- S12.0** Pressure compensated flow control valve SRE1 with pre-set flow rate = 12.0 l/min (Part No. 555040)

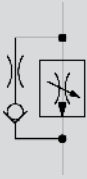

For further technical details, see brochure no. 5.118./...

7.3 PRESSURE GAUGES - supplied loose -



- MA1** Pressure gauge Ø 63 – 160 bar
- MA2** Pressure gauge Ø 63 – 250 bar
- MA4** Pressure gauge Ø 63 – 400 bar
- M** Minimes test point

7.4 ACCUMULATORS - supplied loose -



- SBO1** Accumulator SBO210-0.16
- SBO3** Accumulator SBO210-0.32
- SX** Accumulator, give full details
- AS** Accumulator adapter with orifice Ø 2.0 mm

For further technical details on the SBO, see brochure no. 3.100.19./...

7.2 PRESSURE SWITCHES - supplied loose -



- DS1** Mechanical pressure switch 10 – 100 bar
- DS2** Mechanical pressure switch 50 – 200 bar
- DS3** Mechanical pressure switch 100 – 350 bar
- EDS3** Electronic pressure switch EDS3446-2-250-000 up to 250 bar

For further technical details on the EDS 3000, see brochure no. 18.060.0./...

8. SAFETY INSTRUCTIONS AND DOCUMENTATION

8.1 SAFETY INSTRUCTIONS DURING OPERATION

- Ensure that the unit is only used for its designated purpose
- Do not exceed maximum permitted operating pressure
- Do not exceed maximum permitted oil temperature of 80°C
- Power units and build-on parts can become hot during operation – risk of injury!

8.2 REQUIREMENTS AT THE INSTALLATION SITE

- Permitted ambient temperature range -20 °C to +40 °C
- Ensure adequate ventilation for heat dissipation
- Do not mount power unit to moving parts
- Finish required on mounting surface 0.3 mm over 100 mm length
- To avoid excessive noise, use flexible mounts and avoid mounting on resonating surfaces
- To prevent vibration transfer, hoses must be used wherever possible when connecting the power unit

NOTE

The information in this brochure relates to the operating conditions and applications described. For applications or operating conditions not described, please contact the relevant technical department. Subject to technical modifications.

HYDAC Fluidtechnik GmbH
Justus-von-Liebig-Str.
D-66280 Sulzbach/Saar
Tel: 0 68 97 /509-01
Fax.: 0 68 97 /509-598
E-Mail: flutec@hydac.com

